

M-6i™

Basic Description

Six-axis, modular construction, electric servo-driven robot designed for a variety of manufacturing and system processes. The FANUC M-6i robot is engineered for precision, high-speed operation, user-friendly setup and maximum reliability supported by our extensive parts and service network.

M-6i, the Solution for:

- Material handling
- Material removal
- Dispensing
- Machine load/unload
- Assembly
- Waterjet cutting

Benefits

- Floor, invert, wall and angle mounting permits versatility when unusual workpiece access is required
- Slim profile facilitates placement in tight surroundings
- Absolute serial encoders eliminate the need for calibration at power-up
- Highest speed in robot class provides maximum performance and productivity
- Extremely large work envelope (1368mm reach, 940mm horizontal stroke) allows manipulation of larger parts
- Extremely rigid design allows precise positioning



Features

- 6 axes of motion
- 6kg (13.2 lbs) payload capacity
- $\pm 0.1\text{mm}$ ($\pm 0.004''$) repeatability

Reliability Features

- Sealed drives and bearings minimize maintenance
- Grease fittings on all lubrication points for quick and easy maintenance
- All motors, cables and tooling services are enclosed to prevent snagging and damage from chips, sprays and other hazards
- Uses directly coupled drives, which are more reliable than belts, pulleys or chains

- In-line wrist design minimizes complexity and eliminates bevel gear adjustments

Options

- Fail-safe brakes on all six axes increase safety, functionality and control
- 360° Axis 1 base rotation
- Severe dust and liquid protection package for die cast spray, waterjet cutting and other harsh environment applications

FANUC
Robotics

M-6i Dimensions

Top

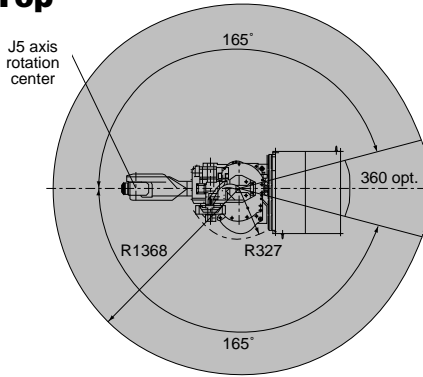

Side

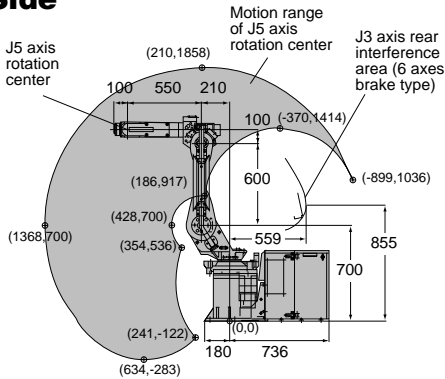

Isometric

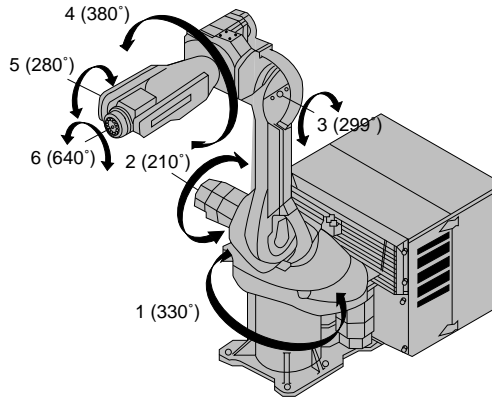

Front

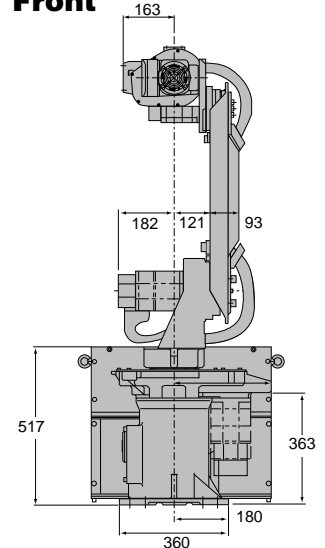

Footprint

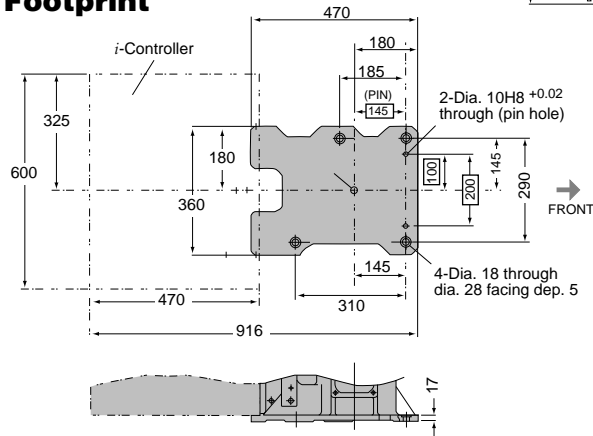

M-6i Specifications

Items		Range	Speed
Motion range and speed (1)	Axis 1	330°	120°/sec
	Axis 2	210°	120°/sec
	Axis 3	299°	120°/sec
	Axis 4	380°	360°/sec
	Axis 5	280°	360°/sec
	Axis 6	640°	450°/sec
Wrist Moments	Axis 4	1.6kg • m	
	Axis 5	1.0kg • m	
Wrist Load inertias	Axis 4	6.40kg • cm • s ²	
	Axis 5	2.00kg • cm • s ²	
Wrist Load inertias	Axis 6	0.62kg • cm • s ²	
	Repeatability	±0.1mm (±0.004")	
Maximum load wrist capacity	6kg (13.2 lbs)		
Mounting method (3)	Upright, inverted, angle, wall		
Maximum stroke	940mm (37") largest in its class		
Mechanical Brakes (4)	Axes 2 and 3		
Mechanical Weight	290kg (638 lbs) including i-controller		

- (1) Axis 1 360° rotation is optional
- (2) For wall, shelf and angle mounts, brakes on all six axes are required
- (3) Reach is derated for angle and wall mount
- (4) Brakes on axes 1, 4, 5 and 6 are optional

Mounting Plate

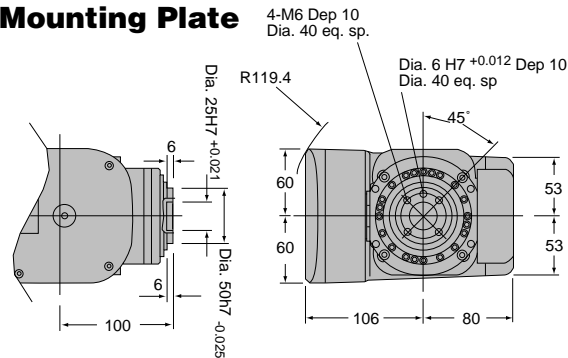

Note: Not to Scale
All dimensions in metric (mm)

FANUC

Robotics

FANUC Robotics North America
3900 W. Hamlin
Rochester Hills, MI 48309
Phone (248) 377-7000
Fax (248) 377-7366

Cincinnati, OH
Phone (513) 771-8844

Toronto, Canada
Phone (905) 670-5755

Chicago, IL
Phone (630) 876-5600

Montréal, Québec
Phone (514) 492-9001

Literature Request
1-800-47-ROBOT

Los Angeles, CA
Phone (714) 595-2700

Mexico City, Mexico
Phone (52-5) 611-5998

Charlotte, NC
Phone (704) 596-5121

Sao Paulo, Brazil
Phone (55)(11) 3067-8070

e-mail address: fanuc.robotics@industry.net
web page: <http://www.industry.net/fanuc.robotics>